

CUSTOM CONTROL SENSORS, INC.

645DB INSTALLATION INSTRUCTION

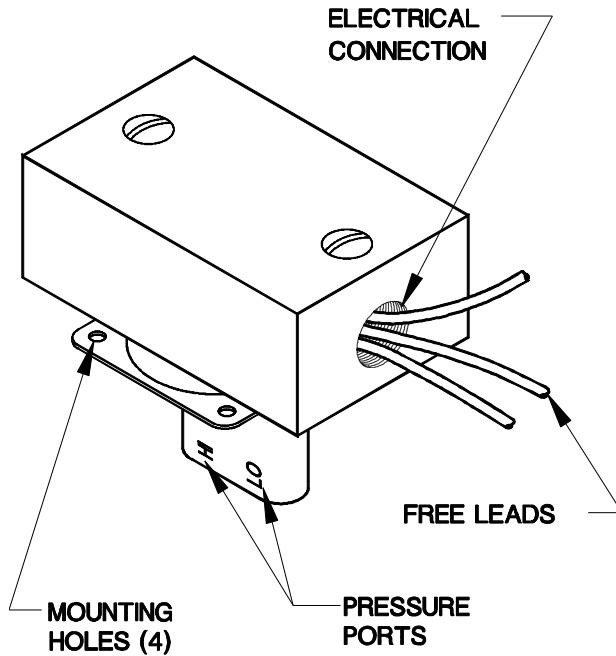

OPEN CIRCUIT CONDITION ON ALL ATTACHED CIRCUITS. DO NOT EXCEED NAMEPLATE PRESSURE OR ELECTRICAL RATINGS.

b. Units are supplied with female NPT port suitable for connection to NPT pipe nipples or NPT taper threaded pipe with max. installation torque of 12 ft. lb. CCS recommends use of either a union or bendable tubing. This will eliminate excessive strain on the housing.

c. Pipe joint sealing compound is preferred over Teflon tape. However, either method of sealing is acceptable with proper care to avoid introducing sealing material into pressure switch or plumbing.

GENERAL:

a. Observe all Warnings and Cautions contained on the attached Warning Sticker, the Warning Declaration and the CCS Catalog.

b. Follow all applicable federal, state government or industry codes and regulations, pertaining to the use of this device.

MOUNTING:

a. Units may be directly mounted in any position. On a flat surface using (4) mounting holes provided.

WARNING:

INSURE THAT BOTH PRESSURE AND ELECTRICAL CONNECTIONS TO THE UNIT ARE DEACTIVATED AND LOCKED OFF IN THE UNPRESSURIZED AND

ELECTRICAL CONNECTIONS:

WIRING DIAGRAMS

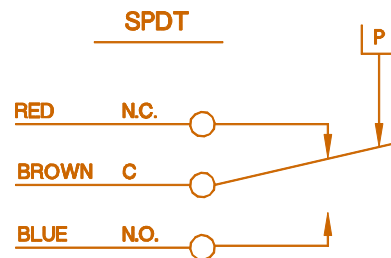

a. When making wire connections disconnect electrical power. Check for multiple circuits.

b. Make electrical connections in accordance with the NEC and all other appropriate codes and regulations. Conduit enclosure shall be wrenchtight or 12 ft. lb. max. torque applied.

WARNING DECLARATION

If this switch is used to protect equipment or personnel from unsafe pressure or to guard against the hazardous release of contained substances it must be installed and operated in accordance with applicable codes, regulations and standards. This switch must be used in conjunction with system design(s) or procedure(s) necessary to mitigate any hazard resulting from its failure. Conform to installation instructions accompanying this switch. Individuals who ignore this warning may suffer serious or fatal injury and do so at their own risk. Custom Control Sensors is not liable for any misuse, abuse, suitability or adequacy of user's application of the switch. Service by qualified personnel only.

WARNING DECLARATION

If this switch is used to protect equipment or personnel from unsafe pressure or to guard against the hazardous release of contained substances it must be installed and operated in accordance with applicable codes, regulations and standards. This switch must be used in conjunction with system design(s) or procedure(s) necessary to mitigate any hazard resulting from its failure. Conform to installation instructions accompanying this switch. Individuals who ignore this warning may suffer serious or fatal injury and do so at their own risk. Custom Control Sensors is not liable for any misuse, abuse, suitability or adequacy of user's application of the switch. Service by qualified personnel only.