

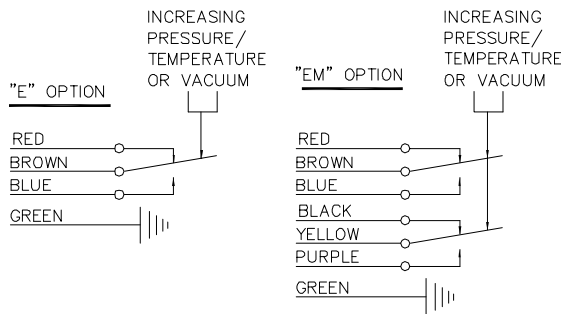

Installation & Maintenance Instruction

Switch Models: 646G*Y*, 646D*Y*, 646P*Y*, 646V*Y*

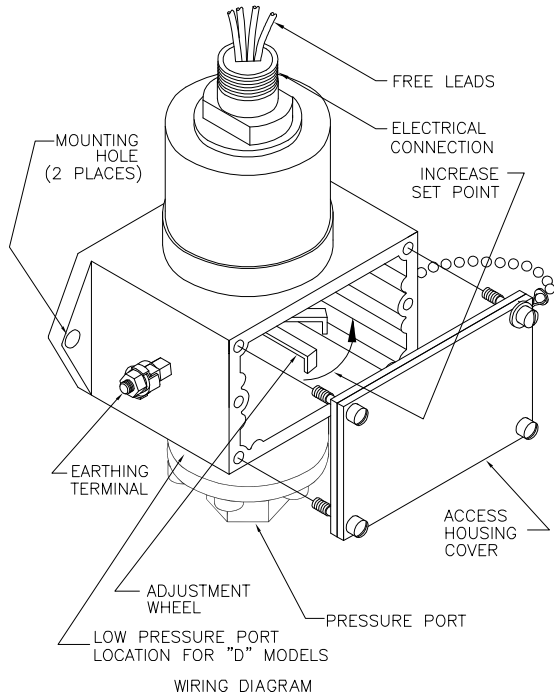

NAMEPLATE ELECTRICAL RATINGS

BODY ASSY.	VOLTAGE	MAX. CURRENT RATINGS (AMPERES)		
		STEADY STATE (MAKE OR BREAK)	IN-RUSH	
			N.C.	N.O.
"E"	125/250/480 VAC	15	30	15
	125 VDC	0.40	40	20
"EM"	125/250 VAC	5	20	20
	28 VDC	5	24	24

FOR SERVICE OR ORDERING INFORMATION

Consult factory or authorized factory representative. Specify full catalog part number (with optional modification) and factory set-point.

WARRANTY

All CCS products and services are sold subject to: "CCS standard terms and conditions of sale".

Custom Control Sensors, Inc

21111 Plummer Street
Chatsworth, CA 91311
Tel: (818) 341-4610 • Fax: (818) 709-0426
<http://www.ccsdualsnap.com>

CCS International

Unit 13, Shrivenham Hundred Business Park
Watchfield, Nr. Swindon, United Kingdom SN6 8TZ
Tel: (+441 793) 783-545 • Fax: (+441 793) 783-532
<http://www.ccsdualsnap.co.uk>

CCS switches are designed to provide long life and maintain excellent set-point accuracy under adverse environmental conditions.

Check Nameplate on the switch for maximum proof (overpressure) or vacuum limits, as shown.

I. GENERAL:

- Observe all Warnings and Cautions contained on the attached Warning Sticker, the Warning Declaration and the CCS Catalog.
- Follow all applicable Governmental or other Codes or Regulations.
- Special Conditions for Safe Use: The integral free lead wires shall or cable be mechanically protected and terminated in a suitable junction or terminal facility.

II. MOUNTING:

- Units may be mounted in any position on a flat surface using (2) mounting holes provided and 1/4" screws at least 3/4" long.

WARNING: RELEASE ALL PRESSURE PRIOR TO INSTALLATION OR REMOVAL OF THIS DEVICE. DO NOT EXCEED NAMEPLATE LISTED PROOF PRESSURES.

- Units are supplied with female NPT ports as standard suitable for connection to NPT pipe nipples or NPT taper threaded pipe. CCS recommends use of either a union or bendable tubing. This will eliminate excessive strain on the housing.

- Pipe joint sealing compound is preferred over Teflon tape. However, either method of sealing is acceptable with proper care to avoid introducing sealing material into pressure switch or plumbing.

III. ELECTRICAL CONNECTIONS:

WARNING: DO NOT MAKE ELECTRICAL CONNECTIONS WHILE ELECTRICAL POWER IS ON. THIS PRODUCT MUST BE INSTALLED BY A QUALIFIED ELECTRICIAN TO AVOID RISK OF ELECTROCUTION.

- Electrical conductors are provided within a male conduit connection.
- When making wire connections disconnect electrical power. Check for multiple circuits.
- Make electrical connections in accordance with the appropriate codes and regulations. Keep as much wire as possible for a service loop to facilitate service, see wiring diagrams.
- Proper grounding must be accomplished by use of the illustrated earthing terminal provided.

IV. ADJUSTMENT:

Pressure settings are externally adjustable. (Not applicable if units are factory set)

- If the electrical circuit cannot be used for testing, disconnect electrical power and use a suitable circuit tester or light box.
- Remove access cover. Rotate adjustment wheel as illustrated with pressure port facing down; turn clockwise to increase settings or turn counterclockwise to decrease setting.
- Re-install access cover; d) Reconnect electrical circuit; e) Return power to unit.

Baseefa 05ATEX0011X



II 2 GD Ex d IIC
T85°C Tamb -34°C/ +71°C
T100°C Tamb -34°C/ +86°C

ELECTRICAL:

ELECTRICAL RATINGS.
WIRING DIAGRAM OPTIONS.

S/N: MO/YR



WARNING DECLARATION

If this switch is used to protect equipment or personnel from unsafe pressure or to guard against the hazardous release of contained substances it must be installed and operated in accordance with applicable codes, regulations and standards. This switch must be used in conjunction with system design(s) or procedure(s) necessary to mitigate any hazard resulting from its failure. Conform to installation instructions accompanying this switch. Individuals who ignore this warning may suffer serious or fatal injury and do so at their own risk. Custom Control Sensors is not liable for any misuse, abuse, suitability or adequacy of user's application of the switch. Service by qualified personnel only.